

WP6

All SS (SS 316) Pressure Gauge
Bourdon type



Standard Version



With External
Zero Adjustment



CE

Special Features

- External zero adjustment (optional)
- Stainless steel case & measuring system
- Socket directly welded to case
- Dry and liquid filled version
- Standard followed EN 837-1 (for NS 100, 150 & 250 mm)
- CE marking (as per PED 97/23/EC) (for NS 100 mm & 150 mm)

Application

- Food & beverage
- Pharmaceutical
- Cryogenics
- Pumps
- Diesel engines & Refrigerating plants
- Chemical & Petrochemical industries
- Conventional & nuclear power plants
- Environments & gaseous or liquid media that will not obstruct the pressure system.
- Hydro-cleaning machines
- Presses
- Engine compressors
- Turbines
- Suitable for corrosive

Specifications

Standard Version : 100 mm, 125 mm, 150 mm, 200 mm & 250 mm

Accuracy	:	±1.0% of F. S.
Ambient temperature	:	- 25°C to + 65°C
Process temperature	:	Max 300°C
Operating pressure range	:	75% of Scale Value
Over pressure limit	:	< 100 bar : 125% of Max. Scale Value
	:	> 100 to < 600 bar : 115% of Max. Scale Value
	:	> 600 to < 1600 bar : 110% of Max. Scale Value

Case & Bezel	:	AISI 304 SS (Bayonet Type)
Bourdon	:	AISI 316 SS or AISI 316L SS if NACE Option Select
Socket	:	AISI 316 SS (Directly Welded to Case) or AISI 316L SS if NACE Option Select
Movement	:	AISI 304 SS
Joints	:	Tig Argon Arc Welding

Protection	:	IP 68
Dial	:	Aluminium, black graduation on white background
Pointer	:	Aluminium, black coloured Micrometer zero adjustable
Window	:	Toughened Glass
Blow off Disc	:	Neoprene
Gasket & Filling Plug	:	Neoprene

Dry But Fillable Version (Option DFG)

Fillable Dampening Liquid	:	Glycerine 99.7% (Option - DFG)
Ambient Temperature	:	Maximum 65°C
Process Temperature	:	Maximum 65°C
Window	:	Plexi Glass
Other Features	:	Refer Specification of Standard Version

Glycerine Filled Version (Option LFG)

Accuracy	:	±1.0% of F.S.
Ambient Temperature	:	Maximum 65°C
Process Temperature	:	Maximum 65°C
Window	:	Plexi Glass
Dampening Liquids	:	Glycerine 99.7% (others available as option)
Other Features	:	Refer Specification of Standard Version

Temperature effect:

The variation of indication caused by effects of temperature is to be calculated by below formula; which is to be added in the specified accuracy while measurement :- Formula : $\pm 0.04 \times (t_2 - t_1) \%$ of F. S. where t_1 = reference temperature (+20°C) and t_2 = ambient temperature in °C.

Dimensions - Standard Version

TYPE 1

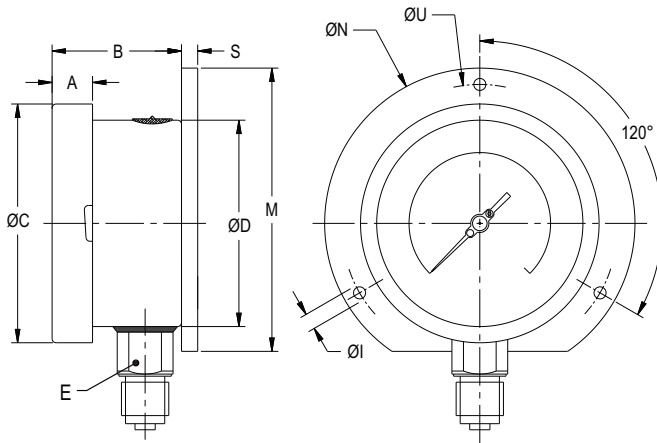

NS	A	B	ØC	ØD	E	M	S	ØI	ØN	ØU	Weight in gram (With Box)	Weight in gram (With Glycerin & Box)
100	12.5	45	111	100	22	128	5	6	134	118	720.0	1025.0
125	15	46	129	119	22	143	5	6	150	137	845.0	1165.0
150	15	47	161	149	22	174.5	5	6	186	168	1160.0	1895.0
200	18	49	216	200	22	229	1.5	7	245	230	2020.0	2780.0
250	18	55	262	247	22	286.5	1.5	7	290	276	2400.0	3220.0

TYPE 2

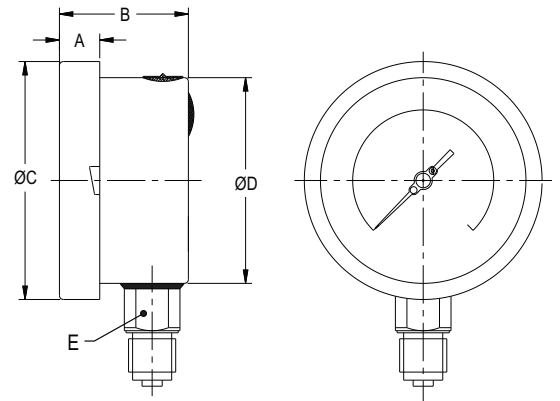

NS	A	B	ØC	ØD	E	Weight in gram (With Box)	Weight in gram (With Glycerin & Box)
100	12.5	48	111	100	22	640.0	935.0
125	15	48	129	119	22	750.0	1070.0
150	15	49	161	149	22	1020.0	1755.0
200	18	49	216	200	22	1720.0	2480.0
250	18	55	263	248	22	2000.0	2820.0

TYPE 3

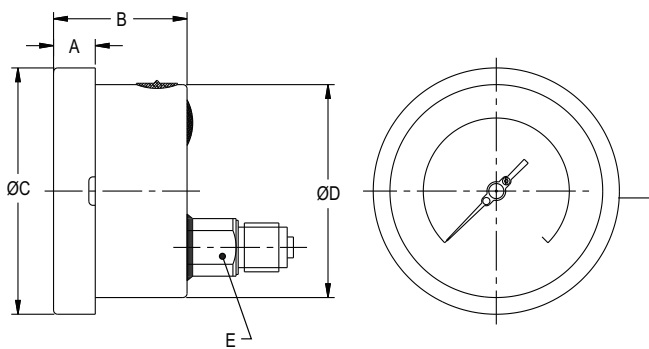

NS	A	B	ØC	ØD	E	Weight in gram (With Box)	Weight in gram (With Glycerin & Box)
100	12.5	47	111	100	22	640.0	935.0
125	15	48	129	119	22	750.0	1070.0
150	15	49	161	149	22	1000.0	1735.0
200	18	49	216	200	22	1500.0	2260.0
250	18	52	263	248	22	1800.0	2620.0

TYPE 4

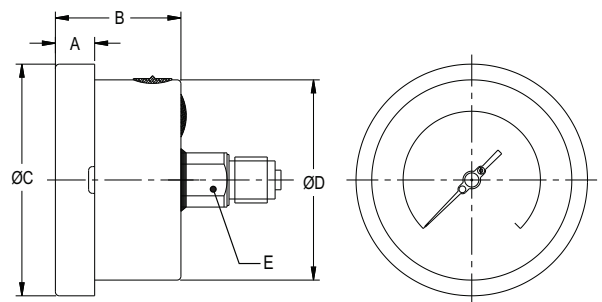

NS	A	B	ØC	ØD	E	Weight in gram (With Box)	Weight in gram (With Glycerin & Box)
100	12.5	47	111	100	22	640.0	935.0

Dimensions - standard version

TYPE 5

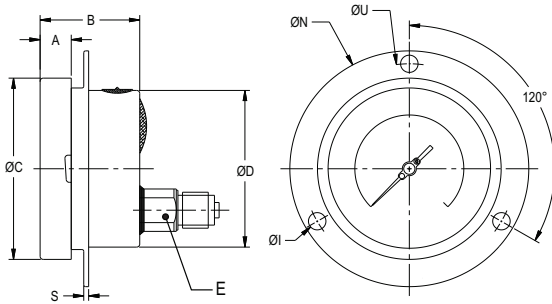

TYPE 11

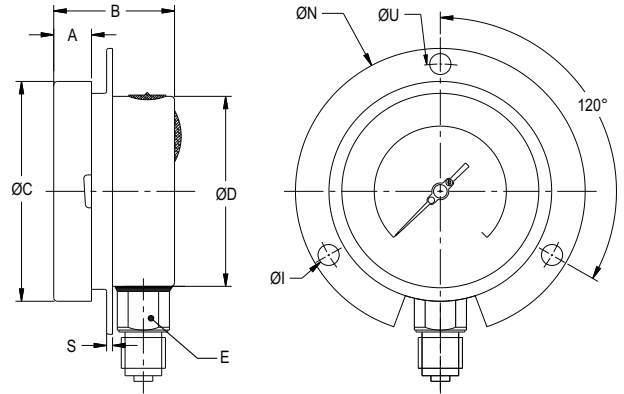

NS	A	B	ØC	ØD	E	S	ØI	ØN	ØU	Weight in gram (With Box)	Weight in gram (With Glycerin & Box)
100	12.5	48	111	100	22	1	6	134	118	695.0	990.0
125	15	48	129	119	22	1	6	150	137	850.0	1170.0
150	15	49	161	149	22	1	6	186	168	1100.0	1835.0
200	18	49	216	200	22	1.5	7	245	230	2000.0	2760.0
250	18	52	263	248	22	1.5	7	290	276	2250.0	3070.0

NS	A	B	ØC	ØD	E	S	ØI	ØN	ØU	Weight in gram (With Box)	Weight in gram (With Glycerin & Box)
100	12.5	48	111	100	22	1	6	134	118	730.0	1025.0
125	15	48	129	119	22	4	6	150	137	815.0	1135.0
150	15	49	161	149	22	5	6	186	168	1100.0	1835.0

TYPE 9

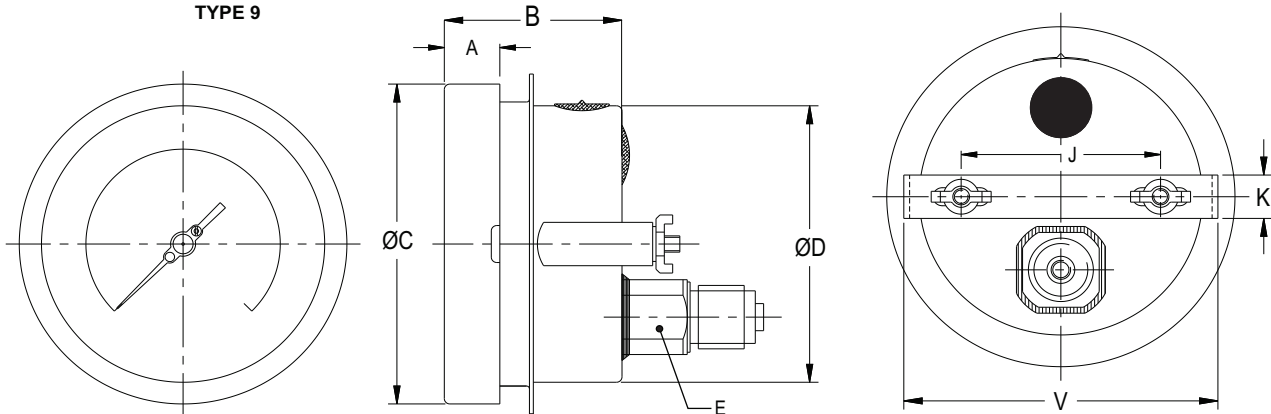

NS	A	B	ØC	ØD	E	J	K	V	Weight in gram (With Box)	Weight in gram (With Glycerin & Box)
100	12.5	48	111	100	22	62	16	108	740.0	1035.0
125	15	48	129	119	22	65	16	125	890.0	1210.0
150	15	49	161	149	22	100	16	166	1100.0	1835.0
200	18	49	216	200	22	165	16	208	1920.0	2680.0
250	18	52	263	248	22	180	30	270	2300.0	3120.0

Notes : • Drawings are not to scale. • All Dimensions are in mm . • NS = Nominal size
• Weights mentioned are approximate and for standard product. Weight can be different after selection of options.

Range Table

Note : We offer National / International Scales like kPa, MPa, bar, psi, kg/cm² & Dual Scale like kPa with psi, kPa with bar, bar with psi or Equivalent scales as per the requirement can be provided on request. Following are the example tables for kg/cm² & psi scales.

Pressure

Single Scale (kg/cm² or bar)

0/0.6	0/4	0/25	0/160	0/1000
0/1	0/6	0/40	0/250	0/1600
0/1.6	0/10	0/60	0/400	
0/2.5	0/16	0/100	0/600	

Dual Scale (psi with kg/cm²)

psi	kg/cm ²	psi	kg/cm ²	psi	kg/cm ²
0/15	0/1	0/400	0/28	0/4000	0/280
0/30	0/2	0/500	0/35	0/5000	0/350
0/60	0/4	0/600	0/40	0/6000	0/420
0/100	0/7	0/1000	0/70	0/10000	0/700
0/150	0/10	0/1500	0/100	0/15000	0/1000
0/230	0/16	0/2300	0/160	0/23000	0/1600
0/300	0/20	0/3000	0/200		

Vacuum & Compound

Dual Scale (inHg with psi & mmHg with kg/cm²)

inHg with psi	mmHg with kg/cm ²	inHg with psi	mmHg with kg/cm ²	inHg with psi	mmHg with kg/cm ²
- 30/0	- 760/0	- 30/60	- 760/4	- 30/200	- 760/14
- 30/15	- 760/1	- 30/100	- 760/7	- 30/300	- 760/21
- 30/30	- 760/2	- 30/150	- 760/10	- 30/350	- 760/25

Single Scale (kg/cm²)

- 1/0	- 1/1.5	- 1/5	- 1/15
- 1/0.6	- 1/3	- 1/9	- 1/24

Receiver

Linear scale	Square root scale
(0 - 100% Internal Scale)	(0 - 10 Sq - Root Internal Scale)
External Scale	External Scale
0.2 - 1 kg/cm ² or 3 - 15 psi	0.2 - 1 kg/cm ² or 3 - 15 psi
(0-100% linear scale)	(0.2 - 1 kg/cm ²)

Freon (with temperature scale)

Ammonia (with temperature scale)

Note : For temperature scales, please provide refrigerant name.

Range (psi)	(kg/cm ²)	(psi)
-30 inHg - 150	0-300	-1to12.5
-30 inHg - 300	0-500	-1to16
		-1to25
		0 - 300

Accessories (refer datasheet for complete specifications)

CT Cooling tower	GS Over load protector (gauge saver)**	SN Snubber
GC Gauge cock	* Needle valve	SP Siphon

* Refer catalogue for Valves & Manifolds.

** For Pressure Ranges.

Note : For Any Non Standard or Special Scale Marking Consult Factory

How To Order

Example

Basic Model

WP6

Code

Nominal Size

40	45	60	80	100
100 mm	125 mm	150 mm	200 mm	250 mm

XX
or
XXX

Type of Mounting

1	Wall / surface / projection mounting with bottom entry
2	Direct bottom entry
3	Direct lower back entry
4	Direct center back entry (for NS 100 mm only)
5	Lower back entry with front flange
6	2" pipe / yoke mounting with bottom entry*
9	Lower back entry with mounting bracket
11	Bottom entry with front flange (for NS 100 mm, 125 mm & 150 mm)

X
OR
XX

* MOC of bracket and 'U' clamp will be steel (painted). Ask factory for drawings, if required.

Gauge Connection	Nominal Size >	40	45	60	80	100
2BM	¼" BSP (M)	✓	✓	✓	×	×
2NM	¼" NPT (M)	✓	✓	✓	×	×
2TM	¼" BSPT (M)	✓	✓	✓	×	×
3BM	3/8" BSP (M)	✓*	✓	✓	✓	✓
3TM	3/8" BSPT (M)	✓	✓	✓	✓	✓
4BM	½" BSP (M) Standard	✓	✓	✓	✓	✓
4NM	½" NPT (M) Standard	✓	✓	✓	✓	✓
4TM	½" BSPT (M)	✓	✓	✓	✓	✓
4MM	M20x 1.5 (M)	✓	✓	✓	✓	✓

XXX

* Standard for NS 100 mm.

Note : Connections like Metric / UNF etc. can be provided on request.

Range

Refer range table

0/10
kg/cm²

Optional Extras

AC5	Accuracy ± 0.5% of F. S. (for dry version)	MTC	Material test certificates***	IVS	Internal vacuum stop
MBS	Monel bourdon & socket (Monel version)**	VPO	ON - OFF type vent plug	REC	Receiver range
DSM	Integral dampening screw (Monel)	IBR	IBR approval #	FRE	Freon range (with temperature scale)
LGF	Dampening liquid glycerine filled	APM	Anti parallax mirror band dial ##	AMO	Ammonia range (with temperature scale)
LSI	Dampening liquid silicon oil filled*	EZA	External zero adjustment	CBS	AISI 316 SS case & bezel
Ep6	Enclosure protection IP 66	STP	SS tag plate	MOS	AISI 316 SS movement
PLG	Plexi glass	TND	Tag No. marking on Dial	BK4	'U' clamp (AISI 304 SS)
STG	Shatterproof/safety glass	HLT	Helium leak test	BKS	'U' clamp (AISI 316 SS)
MDJ	Movement with dampening jelly	CNS	Conformity as per NACE Standard	PY4	2" pipe/yoke mounting bracket (AISI 304 SS)
KEP	Knife edge pointer	TRC	Calibration certificate traceable to National/International standards	PYS	2" pipe/yoke mounting bracket (AISI 316 SS)
MRP	Maximum reading pointer with plexi glass (except option AC5 & for dry version) ◆	OXS	Oxygen service (for dry version)	DFG	Dry But Fillable Version (Glycerin)
PED	CE marking (as per PED 97/23/EC) ◆	CDD	Custom designed dial	DFS	Dry But Fillable Version (Silicon)
DSS	Integral dampening screw (AISI 316 SS)	IOS	Internal over pressure stop		

XxX

* Gasket & Filling plug of for Viton. **Integral dampening screw will be in monel if ordered. Refer option DSM.

***Material test certificates will be provided for wetted parts only with chemical composition testing. For others, please consult factory.

For NS 150 mm & above. Scale shall be marked in kg/cm² or bar single Scale Only Consult factory for any Other scale requirement.

For NS 150 mm & Above. ◆ For NS 100 mm to 150 mm.

Ordering Example: WP6 - XX or XXX - X or XX - XXX - 0/10 kg/cm² - XXX

For other optional items, please contact factory for delivery and minimum order quantity.

Note : Specifications and dimensions given in this product catalogue represents the state of engineering at the time of printing.
Modifications may take place and materials specified may be replaced by others without prior notice.